



AUTONOMOUS WORKSTATION FOR RIG OPERATIONS



ABOUT US

Building the Future of Industrial Automation

Chaifu and Petro Robotics are focused on advancing the future of industrial operations through robotics, automation, and intelligent systems. Our mission is to help industries improve efficiency, safety, and productivity by integrating cutting-edge robotic technologies into real-world environments.

We combine engineering, automation, and AI-driven innovation to develop solutions that reduce operational risk, optimize performance, and support the next generation of industrial infrastructure. From energy and manufacturing to complex field operations, we are committed to creating smarter systems for a more efficient future.



-  AI-Powered Automation
-  Industrial Robotics Solutions
-  Smart Operational Systems
-  Safety & Efficiency Focus
-  Future-Driven Engineering

We believe the future of industrial operations lies in intelligent automation, safer workflows, and robotics-driven innovation

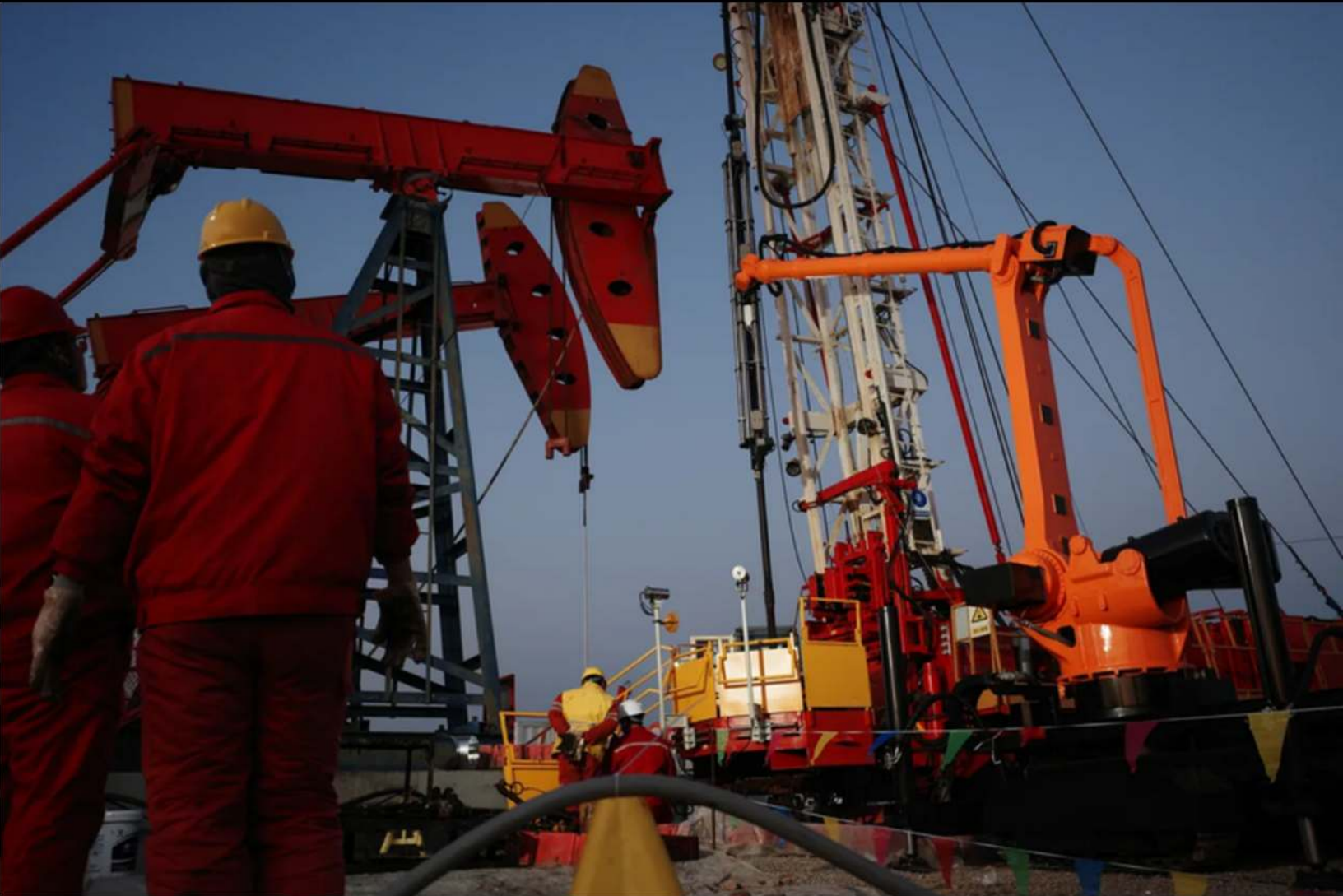

INDUSTRY INSIGHTS & INNOVATION

AI and Robotics Are Transforming Industrial Operations

Across energy, manufacturing, and infrastructure sectors, robotics and artificial intelligence are reshaping how companies operate. Intelligent automation is helping organizations improve safety, reduce downtime, optimize maintenance, and increase operational efficiency. Advanced robotic systems are increasingly being used for inspection, monitoring, predictive maintenance, and complex industrial tasks in challenging environments.

RoboWrangler™ 2000

The World's First Autonomous Workstation for Workover Operations

The New Standard for Rig Automation

The RoboWrangler™ 2000 is an automated workstation built for workover and drilling operations. It pairs an all-electric pipe-handling robot with an electric power tong (IRONCLAW™) to execute pipe transfer, positioning, and makeup/breakout – start to finish – without manual intervention. Explosion-proof by design, it operates across the full range of workover and drilling conditions to handle drill pipe, tubing, and rods of varying specifications. The robot and power tong work in closed-loop synchronization, requiring no operator on the floor and delivering best-in-class positioning accuracy and safety. **The RoboWrangler 2000** integrates with existing wellsite infrastructure – meaningfully raising efficiency, safety, and intelligence on location and online. The RoboWrangler 2000 greatly reduces human exposure to high-risk areas, and reduces physical labor requirements dramatically, multiplying the force of each technician.

Features & Benefits

-  Clear the red zone.
-  Built for harsh oilfield environments.
-  Workover automation.
-  Hands off the wellhead.
-  Robotic wellwork.
-  Eyes on the data.

Continuous Run-Time

Engineered for all-weather, around-the-clock operation, the RoboWrangler 2000 doesn't take breaks.

System-Level Reliability

A fully redundant, closed-loop control architecture stands up to harsh field conditions and delivers fault-free, repeatable performance over long deployment cycles.

Wellhead Risk, Removed

Automated handling replaces the highest-risk manual tasks at the wellhead – keeping the red zone clear, eliminating the most common injuries at the source.

Force Multiplier

Removes physical handling from the critical path, multiplying the effective output of every technician – without scaling crew size or extending shift length.

Technical Specifications

Parameter	Imperial (US)	Metric
Worker Platform Height	~3.28 ft	~1 m
Overall Dimensions — Transport	W 7.55 ft × H 11.15 ft × L 28.38 ft	W 2.3 m × H 3.4 m × L 8.65 m
Overall Dimensions — Working	W 14.60 ft × H 30.35 ft × L 37.95 ft	W 4.45 m × H 9.25 m × L 11.568 m
Arm Reach	23.6 ft	7.2 m
Lifting Height	30.35 ft	9.25 m
Max. Gripping Payload	882 lb	400 kg
Gripping Diameter	Ø ≤ 3.5"	Ø ≤ 89 mm
Pipe Types Handled	Tubing, sucker rods	Tubing, sucker rods
Linear Slide Stroke	16.4 ft	5 m
Pipe Layout Width	32.8 ft	10 m
Climbing Angle	≤ 5°	≤ 5°
Crawler Travel Speed	65.6 ft/min	20 m/min
Total Equipment Power	50.3 HP	37.5 kW
Operating Ambient Temperature	-4 °F to 131 °F	-20 °C to +55 °C
Drive Mode	All-electric robot drive	All-electric robot drive
Workstation Gross Weight	50,706 lb	23 t

Rated voltage: 380 V, 3-phase 50 Hz. US variant available at 480 V / 60 Hz.

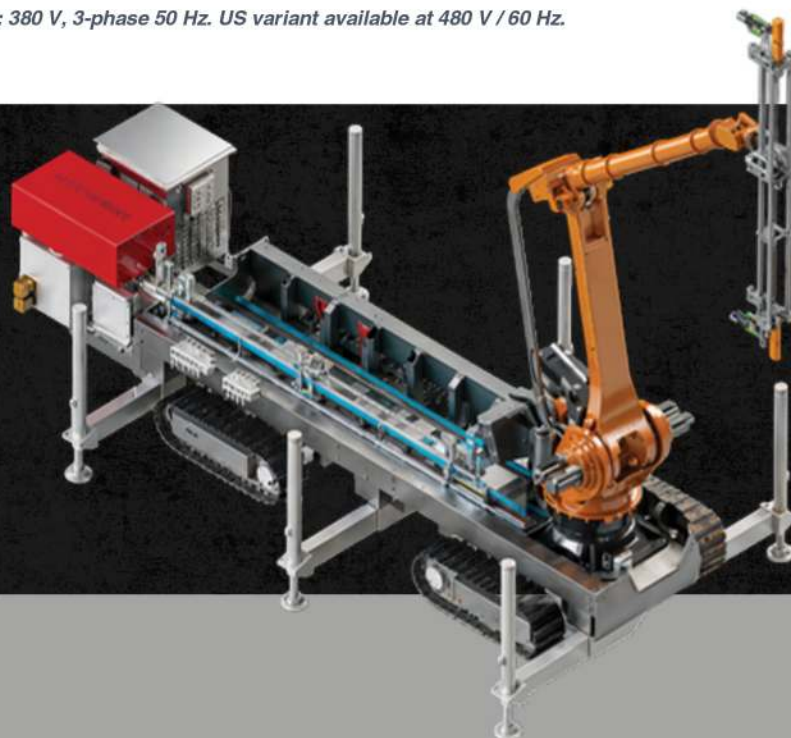

IRONCLAW™ Electric Power Tongs

IRONCLAW™ is an electric power tongs system, purpose-built for making up and breaking out a wide variety of connections. It solves three chronic pain points of manual coupling work: low throughput, inaccurate torque, and red zone exposure. Additionally, maintenance is significantly less than pneumatic or hydraulic systems. **IRONCLAW™** delivers precise, repeatable, and safe makeup and breakout. Utilizing proprietary software, the tongs operate in closed-loop coordination with the RoboWrangler workstation to fully automate the end-to-end process. **IRONCLAW™** can also run standalone, widely adaptable to many rig types, to provide an automated solution that improves safety, efficiency, and reliability.



Key Features: Waterproof, dustproof, and explosion-proof, with a wide operating temperature range. Built for durability and simple maintenance. Engineered to eliminate manual labor and reduce time required making and breaking connections.

Precise & Controllable

Continuously variable speed, precise torque control, and sub-millimeter positioning accuracy ensure perfect handling and torque, eliminating galled threads and connection damage.

Field Ready

Lightweight design makes installation and relocation simple – built for real wellsite conditions. Broad compatibility across various connection types.

Safe & Reliable

Overload protection and anti-fault logic are built in. Simple operation removes the failure modes associated with manual and pneumatic methods.

Adaptable

Engineered to integrate with the RoboWrangler workstation, **IRONCLAW™** also operates as a standalone unit suitable for use with diverse rig packages.

RoboWrangler™ 3000

Low Drill Floor & Workover Pipe-Handling Robot

The RoboWrangler™ 3000 is purpose-built for rig inspection, maintenance, and repair on low drill floors and in workover scenarios. Its compact, highly-mobile chassis allows entry into confined and hazardous spaces beneath the drill floor that personnel can't safely access – performing routine inspection, fault diagnosis, and light maintenance under full automation. The result: lower exposure for crews and a measurable upgrade in maintenance intelligence on drilling platforms.

Technical Specifications

Parameter	Imperial (US)	Metric
Worker Platform Height	~22.97 ft	~7 m
Overall Dimensions — Transport	W 7.55 ft x H 11.15 ft x L 32.8 ft	W 2.3 m x H 3.4 m x L 10 m
Overall Dimensions — Working	W 14.60 ft x H 39.37 ft x L 45.93 ft	W 4.45 m x H 12 m x L 14 m
Arm Reach	34.45 ft	10.5 m
Lifting Height	39.37 ft	12 m
Max. Gripping Payload	3,307 lb	1,500 kg
Gripping Diameter	Ø ≤ 9-5/8" (std US production casing)	Ø ≤ 244 mm
Pipe Types Handled	Tubing, casing, drill pipe, HWDP	Tubing, casing, drill pipe, HWDP
Pipe Layout Width	32.8 ft	10 m
Total Equipment Power	60.3 HP	45 kW
Operating Ambient Temperature	-4 °F to 131 °F	-20 °C to +55 °C
Drive Mode	All-electric robot drive	All-electric robot drive
Workstation Gross Weight	66,139 lb	30 t

Rated voltage: 380 V, 3-phase 50 Hz. US variant available at 480 V / 60 Hz.

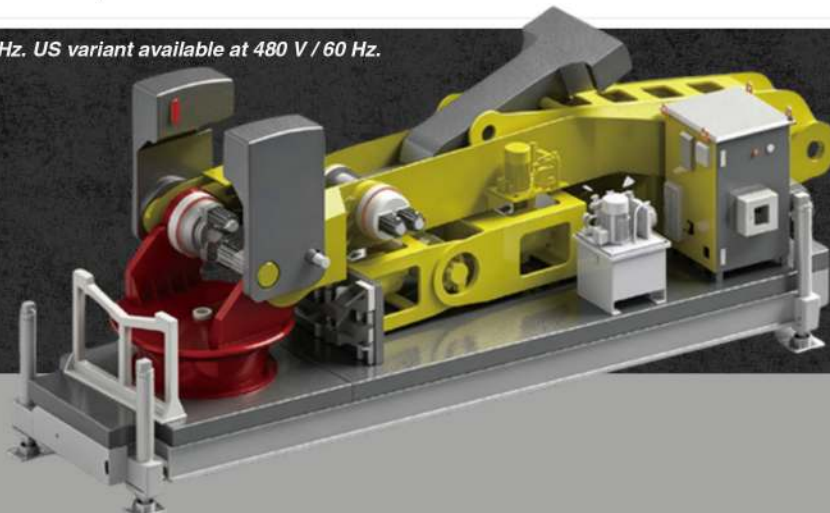

Active Safety Protection

Multiple layers of safety redundancy including intelligent anti-collision sensing and self-locking hydraulic outriggers. Supports emergency stop and adaptive condition-based protection.

Multi-Sensor Fault Diagnosis

Tightly integrated HD vision, infrared thermal imaging, and non-destructive testing modules deliver 360° intelligent identification of surface damage, thermal anomalies, and internal structural defects.





5G + Satellite Remote Operation

Dual-channel high-speed communication via 5G and satellite provide ultra low latency. Technicians operate the robot remotely – handling tasks like bolt tightening and surface cleaning without ever stepping onto the floor.

Engineered for Confined Spaces

Compact chassis designed specifically for low-drill-floor and sub-floor work – accessing the spaces that human crews physically can't, with full automation.

CORE TECHNICAL ADVANTAGES

-  **Compact & Agile**
Tracked or wheeled mobile chassis with a low-profile body. Moves freely through tight spaces and confined equipment zones that personnel can't physically access.
-  **Intelligent Diagnosis**
Combines vision, thermal imaging, and acoustic sensors with AI deep-learning fault detection, moving you from scheduled maintenance to true predictive maintenance.
-  **Remote Operations & Support**
5G and satellite connectivity enable beyond-visual-range control and real-time data streaming. Experts diagnose and resolve faults from anywhere, cutting field travel and downtime.
-  **Standardized, Audit-Ready Maintenance**
Every inspection is recorded and traceable end-to-end – eliminating skipped steps and lifting overall maintenance quality and consistency across the fleet.

RoboWrangler™ 4000

High Drill Floor Pipe-Handling Robot

The RoboWrangler™ 4000 is engineered for high drill-floor environments on full-scale drilling platforms. A heavy-duty, high-precision pipe-handling system, it automates the full sequence – gripping, lifting, transporting, racking, and positioning drill pipe and casing from catwalk to drill floor. It replaces manual pipe handling entirely, delivering a substantial step-change in drill-floor throughput and safety.

Parameter	Imperial (US)	Metric
Worker Platform Height	~36.09 ft	~11 m
Overall Dimensions — Transport	W 7.55 ft × H 11.15 ft × L 42.65 ft	W 2.3 m × H 3.4 m × L 13 m
Overall Dimensions — Working	W 14.60 ft × H 49.21 ft × L 55.77 ft	W 4.45 m × H 15 m × L 17 m
Arm Reach	44.29 ft	13.5 m
Lifting Height	49.21 ft	15 m
Max. Gripping Payload	4,630 lb	2,100 kg
Gripping Diameter	Ø ≤ 9-5/8" (std US production casing)	Ø ≤ 244 mm
Pipe Types Handled	Tubing, casing, drill pipe, HWDP, drill collars	Tubing, casing, drill pipe, HWDP, drill collars
Pipe Layout Width	32.8 ft	10 m
Total Equipment Power	73.8 HP	55 kW
Operating Ambient Temperature	-4 °F to 131 °F	-20 °C to +55 °C
Drive Mode	All-electric robot drive	All-electric robot drive
Workstation Gross Weight	92,594 lb	42 t

Rated voltage: 380 V, 3-phase 50 Hz. US variant available at 480 V / 60 Hz. Repeat positioning accuracy ±0.012" / ±0.3 mm.



CORE FUNCTION ANALYSIS

Automated Pipe Handling

Dedicated clamps and high-precision machine-vision recognition automatically identify drill pipe and casing across a wide range of specifications at the wellsite, then grip them firmly and stably every time.

Intelligent Precision Transport

A 6-axis vertical articulated arm with 13.5 m (44.29 ft) of reach follows pre-programmed motion paths to move drill pipe quickly and stably to its target position on the drill floor.

Automatic Racking & Positioning

Stacks used drill pipe cleanly onto the pipe rack, or pulls pipe from the rack on command – delivering fully automated, intelligent management of the pipe storage area.

Built-In Wellsite Integration

Designed to drop into existing high drill-floor workflows with minimal modification – all-electric, IP67-rated, and field-serviced by Petro Robotics.

CORE TECHNICAL ADVANTAGES

Built on internally developed core technology, RoboWrangler 4000 leads on the metrics that matter – load capacity, positioning accuracy, and environmental tolerance – delivering an automated drill-floor solution that runs efficiently and stably in real field conditions.

Heavy-Duty Load Capacity



Rated at 2,100 kg (4,630 lb) max gripping payload – easily covering the full range of heavy drill-pipe and casing operations up to 9-5/8" OD.

Sub-Millimeter Positioning Accuracy



Powered by Chaifu-developed servo systems, repeat positioning accuracy reaches ± 0.3 mm (± 0.012 " / ± 12 thou) – guaranteeing precise, stable pipe docking every cycle.

24/7 All-Weather Operation



IP67-rated for harsh environments and validated down to -20 °C (-4 °F), the RoboWrangler 4000 runs around the clock in oilfield conditions without interruption.

Engineered & Owned End-to-End



Core components – RV reducers, servo motors, and control systems – are developed in-house by Chaifu, giving Petro Robotics full control over performance, lead time, and field support.

RoboWrangler™ Series

At-a-Glance Model Comparison

One platform, three models — purpose-built for the three job types on every well's lifecycle.

	RoboWrangler 2000	RoboWrangler 3000	RoboWrangler 4000
Job Type	Minor Workover	Major Workover	Drilling
Worker Platform Height	~3.28 ft / ~1 m	~22.97 ft / ~7 m	~36.09 ft / ~11 m
Max Payload	882 lb / 400 kg	3,307 lb / 1,500 kg	4,630 lb / 2,100 kg
Max Gripping Diameter	Ø3.5" / Ø89 mm	Ø9-5/8" / Ø244 mm	Ø9-5/8" / Ø244 mm
Pipe Types Handled	Tubing, sucker rods	Tubing, casing, drill pipe, HWDP	Tubing, casing, drill pipe, HWDP, drill collars
Arm Reach	23.6 ft / 7.2 m	34.45 ft / 10.5 m	44.29 ft / 13.5 m
Lifting Height	30.35 ft / 9.25 m	39.37 ft / 12 m	49.21 ft / 15 m
Mobility	Tracked crawler + outriggers (rolls between wells)	Outrigger positioning (fixed install on rig)	Outrigger positioning (fixed install on rig)
Total Power	50.3 HP / 37.5 kW	60.3 HP / 45 kW	73.8 HP / 55 kW
Operating Temp Range	-4 °F to 131 °F / -20 °C to 55 °C	-4 °F to 131 °F / -20 °C to 55 °C	-4 °F to 131 °F / -20 °C to 55 °C
Drive Mode	All-electric	All-electric	All-electric
Workstation Gross Weight	50,706 lb / 23 t	66,139 lb / 30 t	92,594 lb / 42 t





SCAN FOR A FIELD TEST



CHAIFU

No. 288, Zhenkai Rd.

Zhangyan Town, Jinshan District, Shanghai

P: +86 400 822 7688 E: contact@chaifurobot.com

WWW.CHAIFUROBOT.COM



400 N. Ervay St. Unit# 130084,

Dallas, TX 75313

P: (669) 33-ROBOT (76268) E: hello@petrorobotics.com

WWW.PETROROBOTICS.COM